

SBC 3010

Single Board Computer

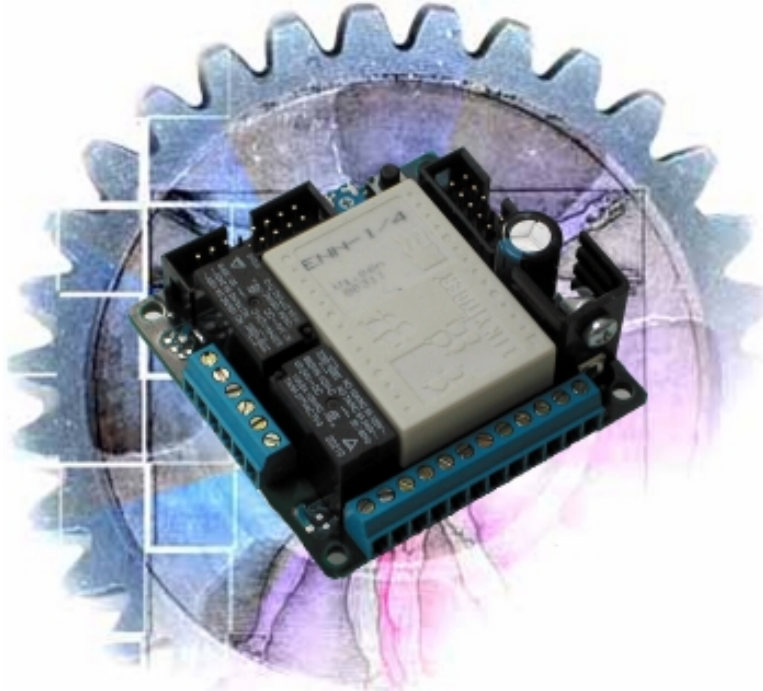

Description: The SBC 3010 allows smaller controls to be realised quickly, at low cost and with a minimum need of external hardware.

The SBC3010 is available for 9...12V or 24V power supply, hence there are numerous possible uses for mobile and stationary deployment.

A 4 x 20 character text LC display can be connected for optical presentation of conditions.

5 free I/O ports, a low- power open drain output and two relay-actuated alteration switches already offer sufficient possibilities for controls. SBC 3010 can be used immediately thanks to the small dimensions, available mounting holes suitable for M3 screws and terminal screws for all I/Os, open drain, RS485 and power supply.

technical data:

controller:

Economy Tiger ENN R/4
with 32 k Ram 512 k Flash

further possible controllers:

ENN -1/4 128k sRam and 512k Flash

ENN -4/4 512k sRam and 512k Flash

supply voltage:

9VDC...12VDC
24VDC

interfaces:

1 x RS232 and 1 x RS485

LC- display:

Connection for 4 x 20 character text
LC- display

SBC 3010

Single Board Computer

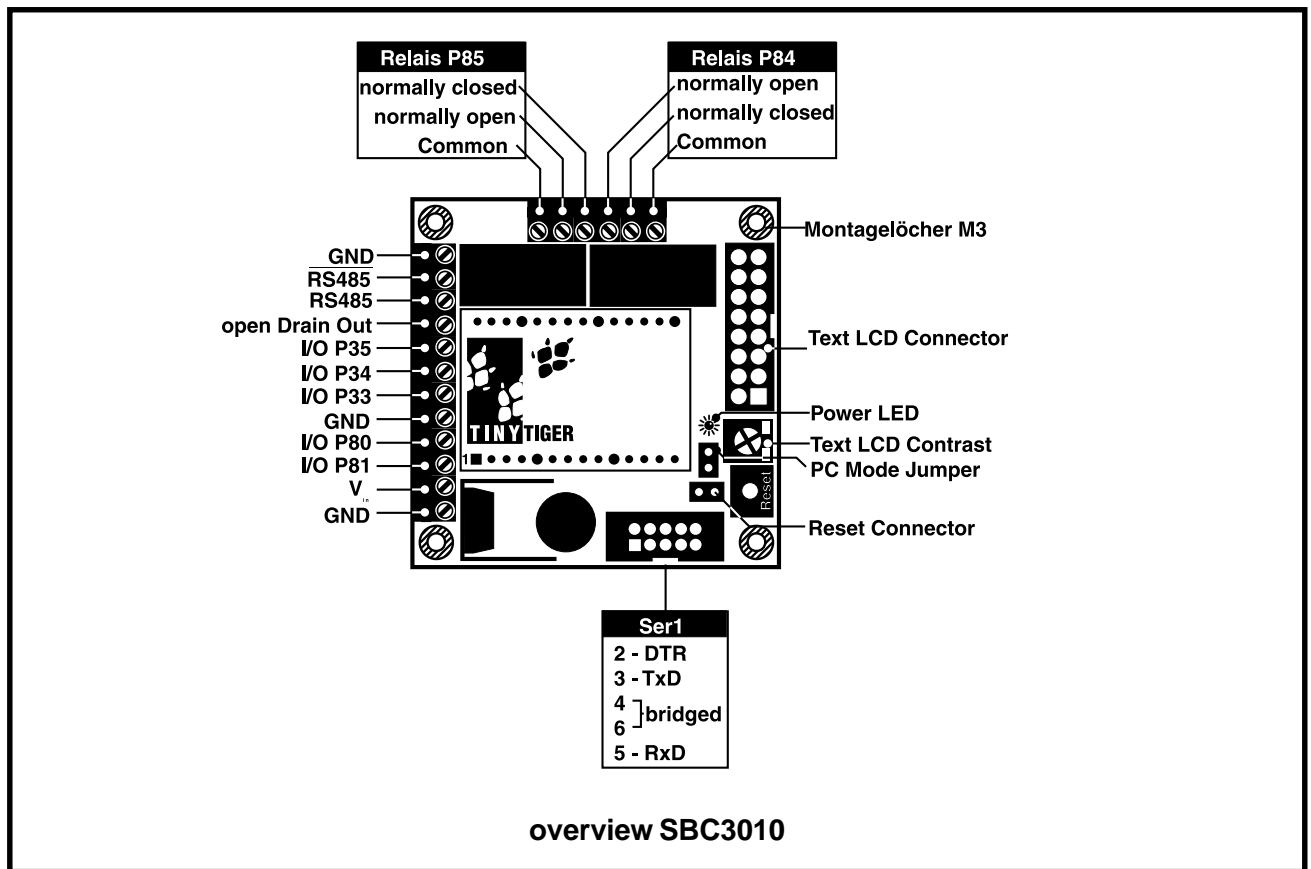

Connections and clamps:

clamps:

GND: (3x) ground

RS485: inverted port of the RS485 interface on Ser0

RS485: notinverted port of the RS485 interface on Ser0

open drain out:

open drain of the low- power FET
 $I_{max} = 0,17A$, $U_{max} = 40V$,
 conductive to GND if P83 = 1

I/O P35: Tiger port 35 5V...24V in, 5V out

I/O P34: Tiger port 34 5V...24V in, 5V out

I/O P33: Tiger port 33 5V...24V in, 5V out

I/O P80: Tiger port 80 5V...24V in, 5V out

I/O P81: Tiger port 81 5V...24V in, 5V out

Relay L85 Relay is controlled by Tiger pin L85. At „1“ on pin L85 the relay picks up. Normally closed: in idle mode (Relay not picked up) connected to Common. Normally open: in idle mode (Relay not picked up) open. Common: mutual connection of alteration switch

Relais P84 Relais wird vom Tiger-Port 84 gesteuert. bei 1 in Port 84 zieht Relais P84 an. normally closed: Im Ruhezustand (Relais nicht angezogen) mit Common verbunden. normally open: Im Ruhezustand (Relais nicht angezogen) offen. common: gemeinsamer Anschluss des Umschalters.

SBC 3010

Single Board Computer

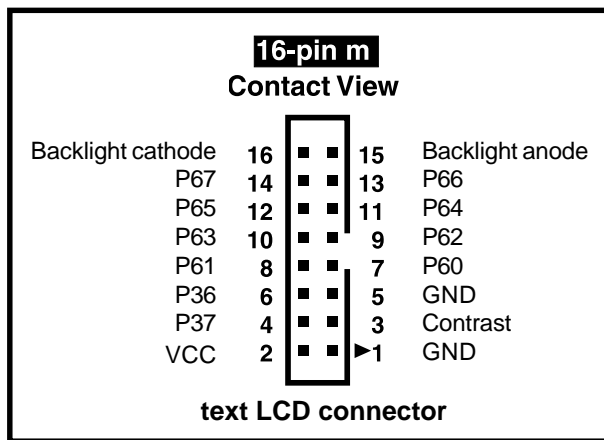

Connections:

Text LC-Display: A text LC display can be connected to the SBC3010 with polarity protection through a 16-pin four-walled header. If no display is connected, the Tiger pins can be used as free I/O pins. The protection circuit (see page 4) is equally implemented on these pins.

- 01- GND ground
- 02- VCC +5V suply voltage for the LC- display
- 03- **contrast:** contrassetting for LCD, must not be misused!
- 04- Port 37 LCD register select, Tiger port 37
- 05- GND ground
- 06- Port 36 LCD enable , Tiger port 36
- 07- P60 adress-/databit 0, Tiger port 60
- 08- P61 adress-/databit 1, Tiger port 61
- 09- P62 adress-/databit 2, Tiger port 62
- 10- P63 adress-/databit 3, Tiger port 63
- 11- P64 adress-/databit 4, Tiger port 64
- 12- P65 adress-/databit 5, Tiger port 65
- 13- P66 adress-/databit 6, Tiger port 66
- 14- P67 Adress-/Databit 7, Tiger Port 67

15- Backlight Anode: Anode for display backlight. It is directly connected to the power supply. A pre-resistor, corresponding to the power supply, must be integrated in the feed line to the LCD:

$$R \approx (V_{in} - 2.9V) / 0.1A$$

16- Backlight Cathode: Cathode for display backlight, directly connected to GND.

Ser1: The serial RS232 interface Ser1 is used in PC mode for programming and debugging the Econo-Tiger. In RUN mode Ser1 can be used as a normal RS232 interface. Ser1 is connected to a 10-pin four-walled header. A 9-pin DSub connector can be directly connected to a flat cable connected here with a pole connector.

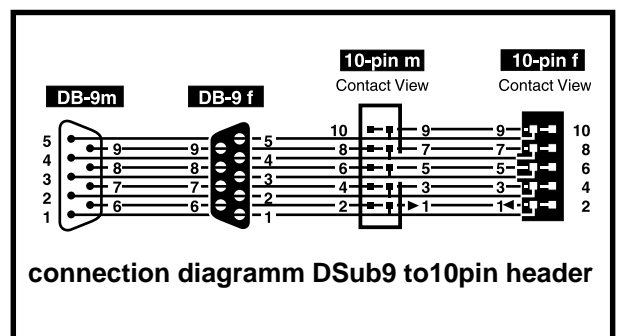
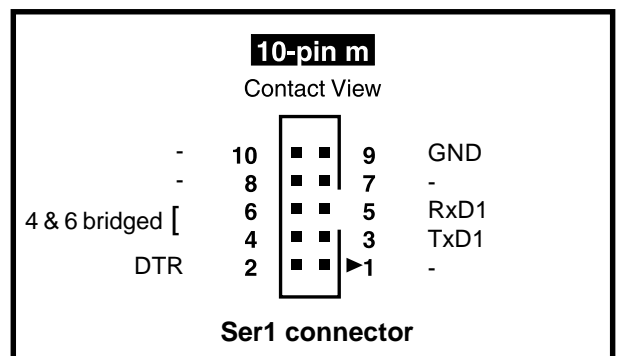

SBC 3010

Single Board Computer

Schutzbeschaltung:

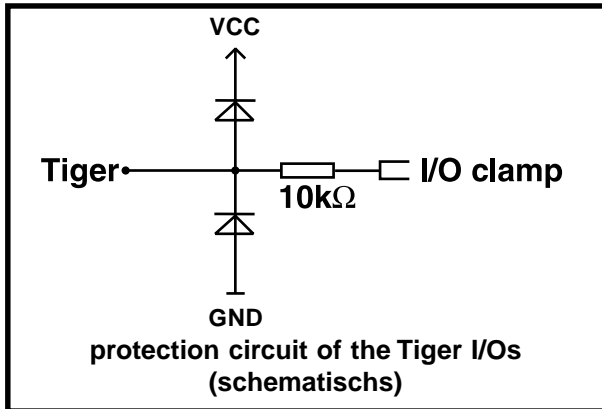

protection circuit of the Tiger I/Os
(schematisch)

Tiger I/Os: all Tiger I/Os are supplied with a protection circuit (see diagram). Voltages > 5.3V are diverted via a Schottky diode with 6,8kΩ pre-resistor to VCC. Voltages < 0.3V are diverted via a Schottky diode to GND.

protected pins: L60...L67, L33...L37, L80, L81

Note: If a Tiger I/O is used as an output, a voltage is released on load through the 10kΩ resistor. If necessary the output signal must be amplified externally. If a Tiger I/O is used as input for signals >5V, the signal source must be able to drive the current, which is discharged through pre-resistor and diode:
$$I_{in} \approx (V_{in} - 5V) / 6,8k\Omega$$

Open Drain Out:

The Open Drain output is protected against too high voltage. Interruptions with negative potential against GND are diverted via a diode to GND. Interruptions > 18V are restricted through a varistor.

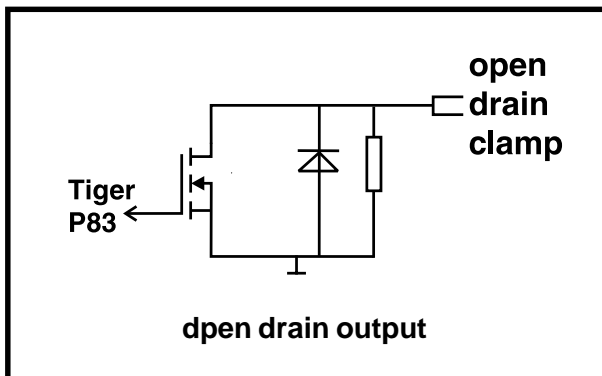

open drain output

Relays:

Description: The SBC3010 is fitted with 2 onboard relays. Both relays are each 1 x alteration switch. Depending on the version of the SBC3010 5V relays are used for the 9...12V version or 24V relays for the 24V version. In the 24V version the relays are supplied directly from the operation voltage. The galvanic isolation of the relay contacts to VCC is 1 kV.

Technical Data:

Coil (5V/24V): Rated power: 0.2W/ 0.4W
Rated current: 40mA/
16.7mA
Resistance: 125Ω/ 1440Ω
 U_{AN} : $\geq 3.75V / \geq 18V$
 U_{AB} : $\leq 0.25V / \leq 1.2V$

Contacts: Number: 1x
alteration switch
 U_{max} : 250VAC

General data: min. lifespan: 10^5 switching cycles
max. number of switching
actuations: 900/h
Response time: 10 ms
Fall time: 5ms

SBC 3010

Single Board Computer

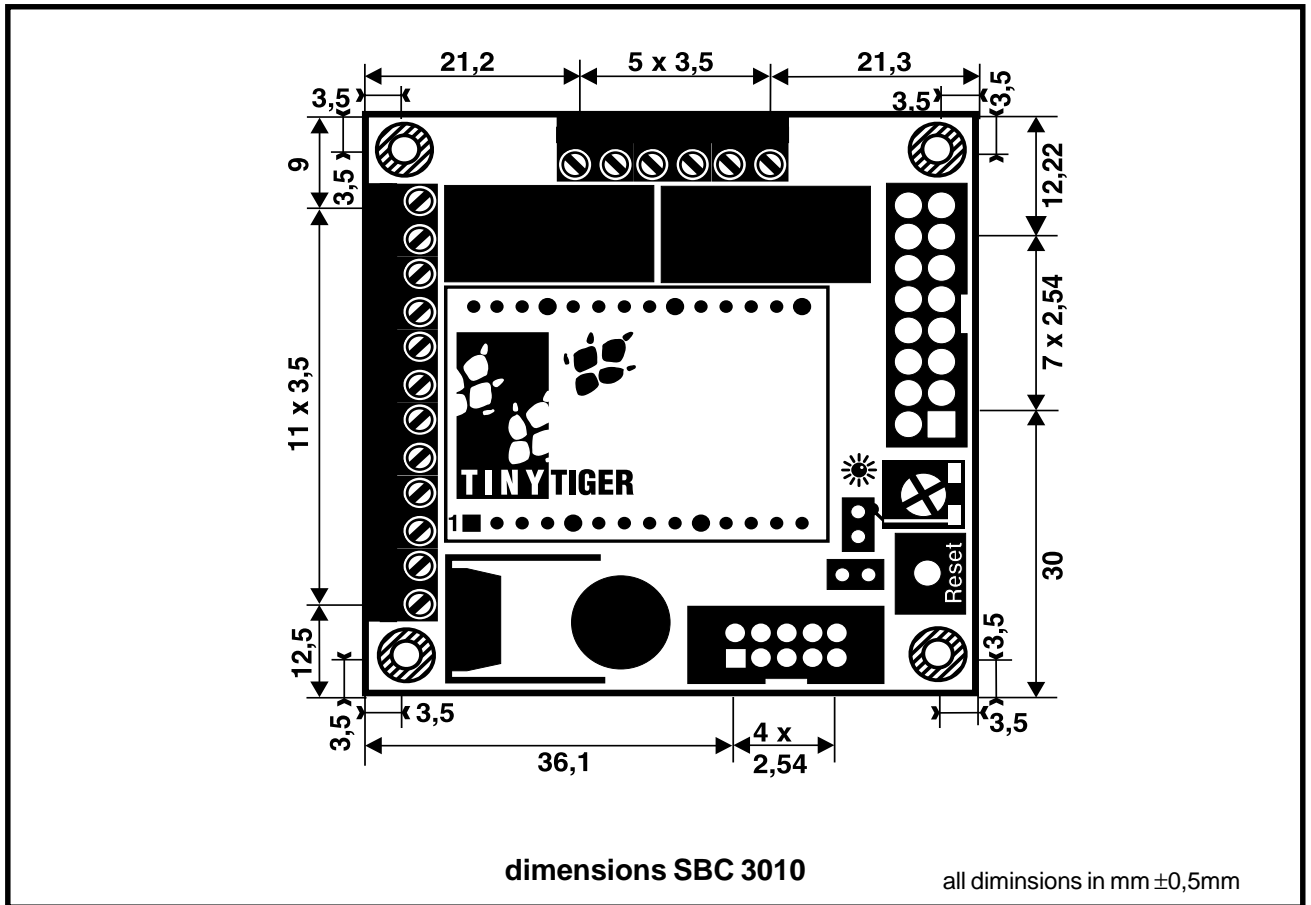

further details:

overall height:	32mm max.
working temperature:	0...85°C
weight:	80g max.
screw terminals:	max. conductor width: 1,5mm ² screw: M2, zinc plated
mounting holes:	4 x 3,2mm

SBC 3010

Single Board Computer

Portmap

Port	Function
Port 60...67	Adress- / Databus for Text LCD
Port 33	Digital I/O 5...24V Hi Level Input / 5V Hi Level Output
Port 34	Digital I/O 5...24V Hi Level Input / 5V Hi Level Output
Port 35	Digital I/O 5...24V Hi Level Input / 5V Hi Level Output
Port 36	Text LCD Enable (E)
Port 37	Text LCD Register select (RS)
PC	PC- /Run Mode Selection
Port 80	Digital I/O 5...24V Hi Level Input / 5V Hi Level Output
Port 81	Digital I/O 5...24V Hi Level Input / 5V Hi Level Output
Port 82	RS 485 Transmit /Receive
Port 83	Low Power FET open Drain Output
Port 84	Relais Output
Port 85	Relais Output
Port 90	Ser 0 TxD out
Port 91	Ser 0 RxD out
Port 92	Ser 0 CTS in
Port 93	Ser 1 TxD out
Port 94	Ser 1 RxD in